



HYPERION Series

- FT-IR Microscopes



HYPERION stands for highest sensitivity at the highest spatial resolution in FT-IR microscopy and chemical imaging. It is designed without compromises, to combine best performance for visible inspection and infrared spectral analysis of any sample.

The HYPERION is the culmination of more than 25 years of experience in FT-IR microscopy. Its high-quality design, including all optical, mechanical, and electronic components, provides high stability and reliability. With its modular design, the HYPERION can be customized for the most challenging R&D applications. Its field of use is extremely broad and includes materials research, polymers, chemicals, forensics, art conservation, and life sciences. Featuring many contrast enhancement tools, a wide variety of dedicated objectives, and chemical imaging, the HYPERION enables you to conduct the most sensitive microanalysis easily and efficiently.

- Highest spatial resolution, limited only by diffraction of light
- Highest sensitivity even at high spatial resolution
- Attenuated total reflectance (ATR) objective with internal pressure sensor and highly accurate and stable column guidance mechanism for precise crystal positioning
- Dedicated grazing angle objective (GAO) with dual pass design for the analysis of thin layers on metallic surfaces
- Automated FT-IR mapping with all measurement modes
- All-in-one spectroscopic software for data acquisition, analysis and documentation
- FT-IR imaging with modern focal plane array (FPA) detector technology

• Sample Visualization

Visual inspection

Before any sample can be analyzed by FT-IR microscopy, the region of interest has to be located on the sample. However, many microscopic samples do not exhibit much contrast in the visible image. The HYPERION provides many different techniques to enhance the contrast for the visible inspection of the sample in transmission and reflection.

To select the most appropriate visualization for a certain sample, the HYPERION is equipped with a nosepiece and a wide variety of objectives. Contrast irises (“Köhler” aperture) are usually the first tool employed to enhance sample observation. Furthermore, rotatable polarizers are available in transmission and reflection that enable the user to distinguish samples exhibiting birefringence. For samples that mostly scatter light, dark field illumination can be applied. To visualize intrinsic fluorescence or fluorescent labels in samples, the HYPERION can also be optionally equipped with fluorescence illumination capabilities. An autofocus function is available to inspect structured sample surfaces.

Viewing devices

The CCD image of the sample is shown not only in the OPUS software on the PC, but also on a second LCD screen integrated in the microscope frame (HYPERION 2000/3000). This second LCD screen makes the sample positioning and the identification of the region of interest in the sample more comfortable. All visual images are saved with the measured infrared spectra and their specific sampling positions. Binoculars are always available on the HYPERION, providing a sample view with highest optical quality. So even on samples with very low visible contrast, the region of interest can be identified.



Contrast enhancement

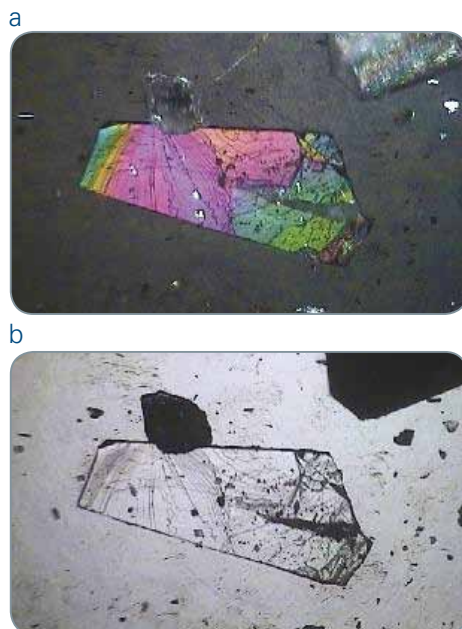

Light images of a geological sample.
a) with crossed polarizers; b) bright field



Integrated LCD screen on the HYPERION makes the sample positioning and the identification of the region of interest more comfortable.

• Sampling Flexibility

For FT-IR microscopic analysis in transmission, most samples must be optically thin and are typically cut in sections about 5–15 μm thick. If samples are deposited on reflective substrates, they are measured in reflection. However, because many samples are not transparent or reflective, they can be readily analyzed utilizing the attenuated total reflection (ATR) mode. For this reason, the quality and usability of the ATR objective is crucial for most applications. Very thin layers (even monolayers!) on reflective surfaces can be analyzed utilizing the grazing angle reflection objective (GAO).

Spectral Range

The spectral range of the HYPERION can be extended from the middle infrared to the near infrared (NIR), even to the visible (VIS, up to $25,000\text{cm}^{-1}$) and down to the far infrared (FIR, down to 80cm^{-1}). To cover this extremely broad spectral range, many different detectors are available and can easily be exchanged by the user. The HYPERION can be equipped with up to two detectors in parallel, where the switching between positions is controlled by the software.

Sample Stages

The HYPERION 1000 is equipped with a manual xy stage; the HYPERION 2000 and 3000 include a very precise and accurate motorized xy stage. Interchangeable rotatable, temperature- (-196 to $600\text{ }^\circ\text{C}$) and humidity- controlled stages are available as an option.



To investigate samples at certain temperatures from -196 – $600\text{ }^\circ\text{C}$, the Linkam THM600 stage can be used. This stage is also controlled by OPUS software.

Optical beampath of HYPERION 1000/2000

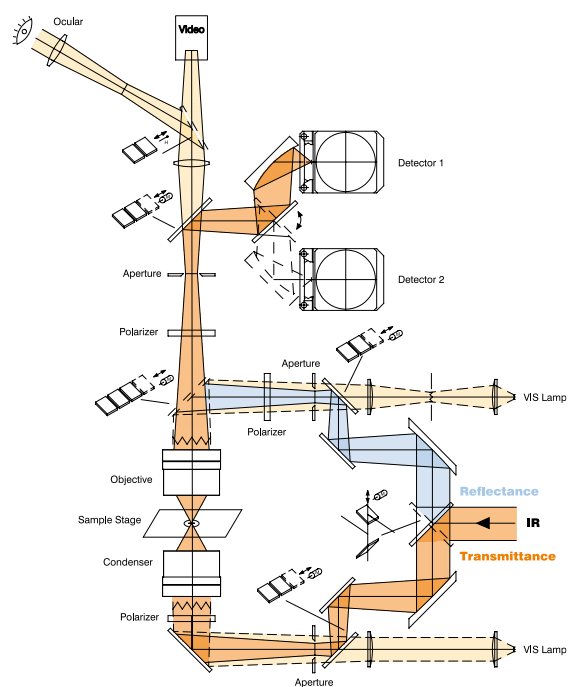

Confocal Design

The HYPERION is designed to achieve the highest sensitivity even at the highest lateral resolution. The infrared beam path is confocal. Apertures can be placed in conjugate image planes individually before and after the sample in transmission as well as in reflection. The spatial resolution for microscopic FT-IR analysis with the HYPERION is only limited by diffraction of the incident light.

In the standard configuration, the HYPERION is equipped with a single transparent knife-edge aperture. Metal knife-edge apertures, iris apertures and aperture wheels are available as well as automatic, software controlled knife-edge apertures. All types of apertures can be easily exchanged by the user.

ATR Objective

The dedicated ATR objective (20x) for the HYPERION allows clear sample viewing without sacrificing infrared light throughput. After the sample positions are defined in the visual image, the ATR crystal is moved on the highly accurate column mechanism to activate the infrared acquisition. The internal pressure sensor reproducibly ensures optimal contact between the sample and the crystal during data acquisition. In combination with the automatic z-drive (option) for the motorized xy stage, even large areas of the sample can be analyzed with high spatial resolution applying automated ATR mapping. To be useful for samples ranging from soft to very hard, different pressures can be selected at the ATR objective. ATR crystals with different tip sizes are available. They are made from materials with a high refractive index (germanium or silicon) that permit even the investigation of dark materials. Furthermore, the ATR crystal acts as a solid immersion lens so that the spatial resolution achieved with ATR is increased by a factor equal to the refractive index of the ATR crystal (germanium = 4) compared with measurements performed in transmission or reflection.

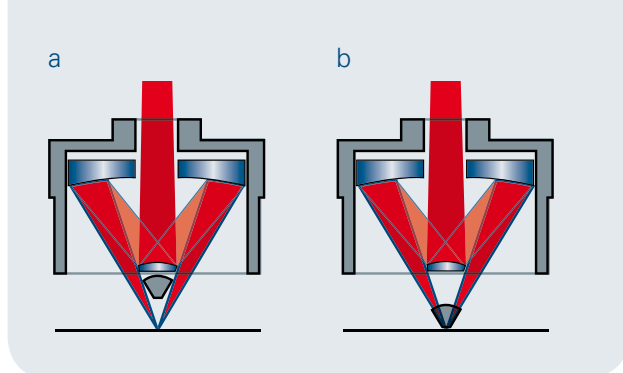

The HYPERION ATR objective has two modes of operation: one for optimal image quality in the viewing mode, and the other for providing maximum IR-light throughput. The internal pressure sensor always guarantees optimal contact between the crystal and the sample.

Grazing Angle Objective (GAO)

The measurement of very thin coatings on metallic surfaces often requires the grazing angle incidence reflection technique. It enhances the interaction of the infrared light with the sample. Bruker's patented grazing angle objective (GAO) achieves very high sensitivity due to the novel use of a folding mirror and dual pass design. The signal intensity is actually doubled during the GAO analysis because the IR beam passes through the sample twice.

Unlike other grazing angle objectives, polarization of the incident light is retained. This property facilitates selective measurements of the absorption of p- and s-polarized light, from which information about the sample orientation can be obtained.

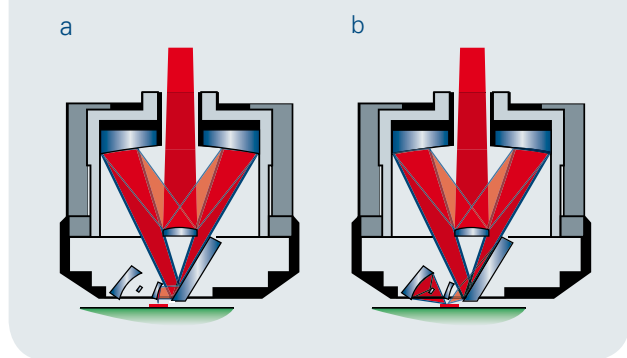

This 15x GAO objective has two modes, one for viewing the sample and the other for infrared data collection. In the viewing mode (a), two parallel plane mirrors displace the focal point to near-normal incidence, providing excellent image quality. In the IR measurement mode, the plane mirrors are moved and the IR beam is reflected on the sample surface at a high angle. After reflecting from the surface, the beam strikes a spherical mirror and is refocused on the same sample spot again before passing back into the objective.

• Chemical Imaging

Chemical Imaging

The HYPERION 3000 combines FT-IR imaging and single point spectroscopy within one microscope. This system includes modern focal plane array (FPA) detector technology utilizing the acquisition of thousands of spectra per second. Even larger sampling areas can be analyzed with highest spatial resolution very fast. High-resolution chemical images can be collected in a matter of just a few seconds. Up to 16,384 spectra can be measured simultaneously, resulting in images of up to $340\ \mu\text{m} \times 340\ \mu\text{m}$. Much larger areas are covered by assembling subsequently acquired IR images using the motorized xy-stage. Because the pixel resolution in the HYPERION 3000 is very high for all available objectives, the resolution power is only limited by the diffraction of light. A large suite of image processing functions is available in OPUS.

FT-IR microscopic imaging: Polymers

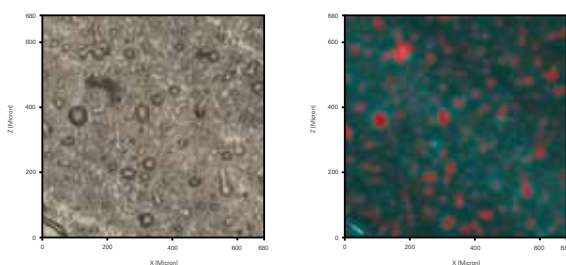

FT-IR microscopic imaging of a two-component polymer mixture spotted on a silicon substrate. The area of $680\ \mu\text{m} \times 680\ \mu\text{m}$ was measured with a pixel resolution of $2.7\ \mu\text{m}$ and a spectral resolution of $4\ \text{cm}^{-1}$ within 8 min, resulting in 65,536 spectra. Left: Visual image of the analyzed area. Right: IR image of the analyzed area showing polymer I in red and polymer II in light blue.

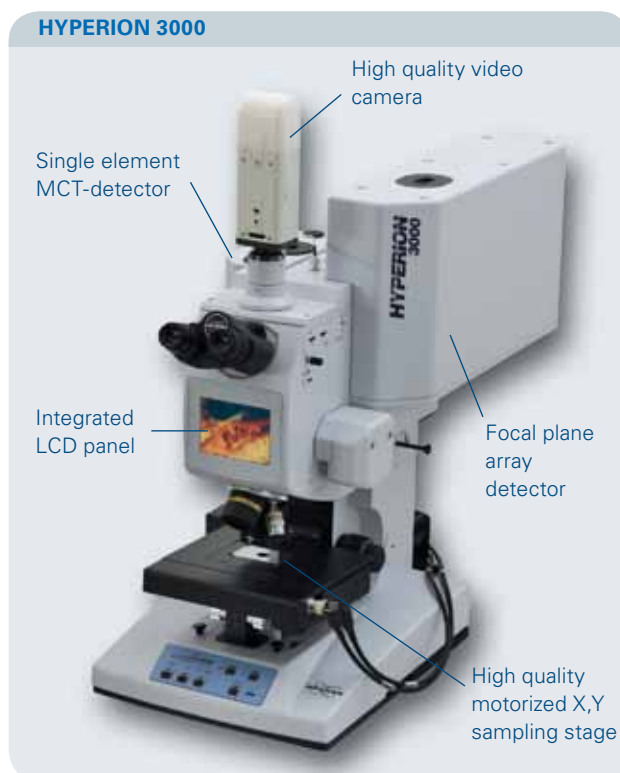

FT-IR microscope imaging: Lateral resolution

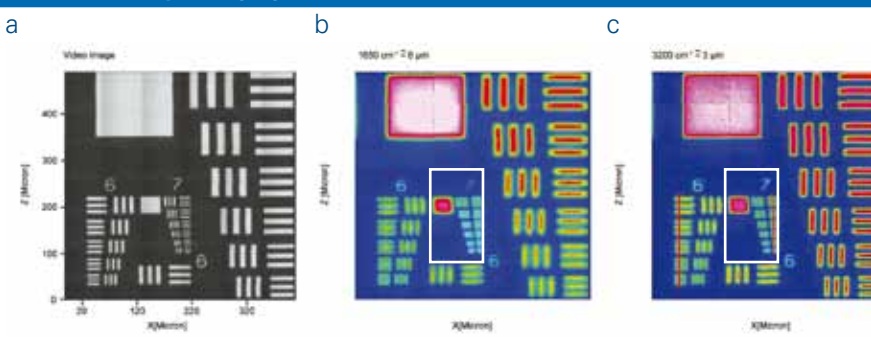

Resolution target (metal stripe pattern on glass, $400\ \mu\text{m} \times 500\ \mu\text{m}$ sampling area) measured in reflection mode with a pixel resolution of $1.1\ \mu\text{m}$ using a HYPERION 3000 with a 64×64 FPA detector and a 36x objective ($\text{NA} = 0.5$). As shown in the IR images at $1,650\ \text{cm}^{-1}$ (b) and $3,200\ \text{cm}^{-1}$ (c), the achieved lateral resolution is only limited by the light diffraction (see framed area).

• OPUS Software

The HYPERION is controlled by the OPUS software; an easy-to-use, powerful, all-in-one spectroscopy software. It includes the most comprehensive collection of data acquisition, processing, and evaluation functions. The software user interface can be customized for routine laboratory analysis as well as advanced R&D applications.

All resultant spectra, visual images, IR images, RGB and PCA plots, and annotations are stored within one file to ensure data integrity and make data manipulation straightforward.

Data acquisition using the HYPERION is very easy to accomplish, as it is guided by attractive wizards (OPUS 7.0). Many univariate and multivariate algorithms are implemented in OPUS to extract the relevant information out of the measured single or 3D data. Resulting IR images can be displayed in different 2D and 3D perspectives on top or beside the visible image.

Spectrometer Diagnostic

Only a constantly monitored spectrometer system can guarantee the acquisition of reliable data. Therefore, OPUS includes permanent online diagnostics, “real-time” display of the instrument status, and integrated automatic instrument tests (OQ, PQ). Hardware and software are fully validated.

OPUS features for FT-IR microscope and imaging:

- Wide variety of 2D/3D views for 3D and 4D data
- IR images in 2D/3D on top or next to the video images of the sample
- Calculation and visualization of RGB images, PCA analysis, 3D cluster analysis, artificial neural nets (ANN), etc.
- Correlation of 3D data with single-component spectra
- Automated mapping and imaging
- Powerful library search tools and many spectral libraries
- Many interactive functions also for 2D/3D files
- Customized workspaces

Validation

Today’s regulated laboratory and process environments must comply with extensive regulatory requirements. Providing multiple user support, electronic signature records, a high level of security, and many other required features, OPUS is a fully validated software and fulfills all 21 CFR Part 11 requirements.

ATR-microscopic mapping

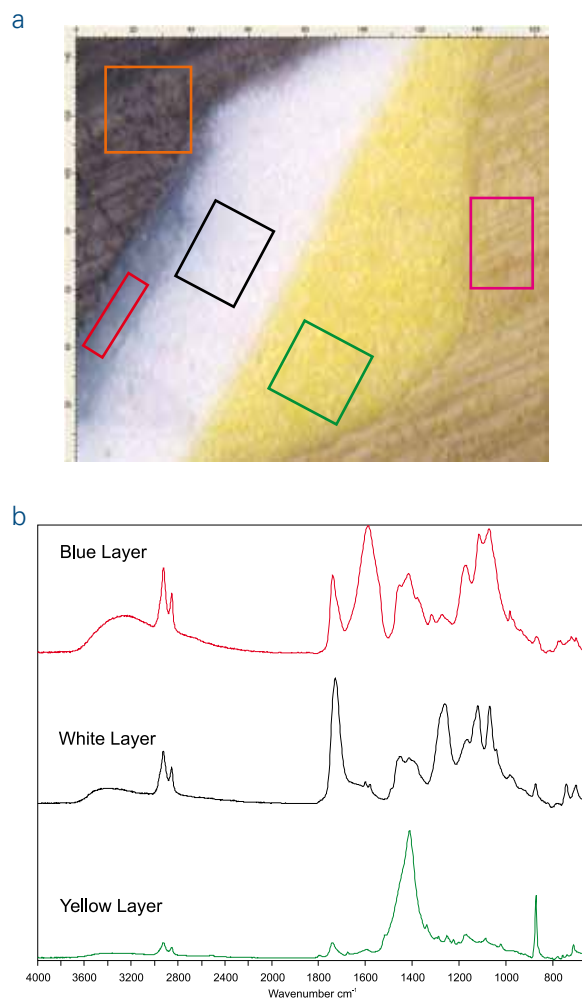

ATR microscopic mapping of a paint chip: To result in characteristic spectra for all layers, the regions of interest were defined by software first. The spectra were measured automatically with the ATR objective, whereas the sampling areas were narrowed by the motorized knife-edge aperture. Representative spectra for three layers, measured in seconds, are shown below the visible image above.

• Bruker Optics



The spectral range of the HYPERION can be extended into the VIS on one end, and to the FIR on the other end. Here, a HYPERION is shown that has a helium-cooled Bolometer for FIR measurements mounted on the second detector position.

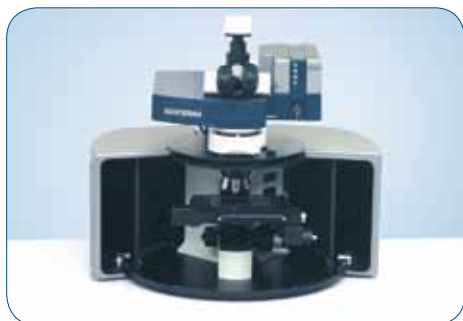

SENTERRA Raman microscope provides permanent wavelength calibration, fluorescence rejection and on-demand confocal imaging. Its open architecture allows coupling to inverse microscope, AFM and z-stage for special applications.

Support, Training, and Service

Application Support

Bruker Optics is staffed mainly by scientists and engineers with in-depth knowledge of the science and instrumentation used in the field. Our product specialists are ready to offer advice concerning the use of sampling attachments, choices of optical components, and software procedures. Furthermore, we at Bruker specialize in close cooperation with our customers in the development of spectroscopic techniques.

Training

Customer training courses are held on a regular basis for the benefit of the instrument users. Customized on-site training is also available from our staff of application specialists.

Service

Bruker Optics spectrometers are intended to provide years of trouble-free operation. Should a problem occur, a network of Bruker companies and representatives around the world is ready to respond to your needs. Professional installations and a high standard of post-delivery service are commitments Bruker Optics makes to each of its customers.

**Bruker Optics
is ISO 9001 certified.**

Lasers class 1 product

www.bruker.com/optics

• **Bruker Optics Inc.**

Billerica, MA · USA
Phone +1 (978) 439-9899
Fax +1 (978) 663-9177
info@brukeroptics.com

• **Bruker Optik GmbH**

Ettlingen · Germany
Phone +49 (7243) 504-2000
Fax +49 (7243) 504-2050
info@brukeroptics.de

• **Bruker Hong Kong Ltd.**

Hong Kong
Phone +852 2796-6100
Fax +852 2796-6109
hk@brukeroptics.com.hk